

# nifty

## SD64

### Operating & Safety Instructions MODEL SD64 SERIES

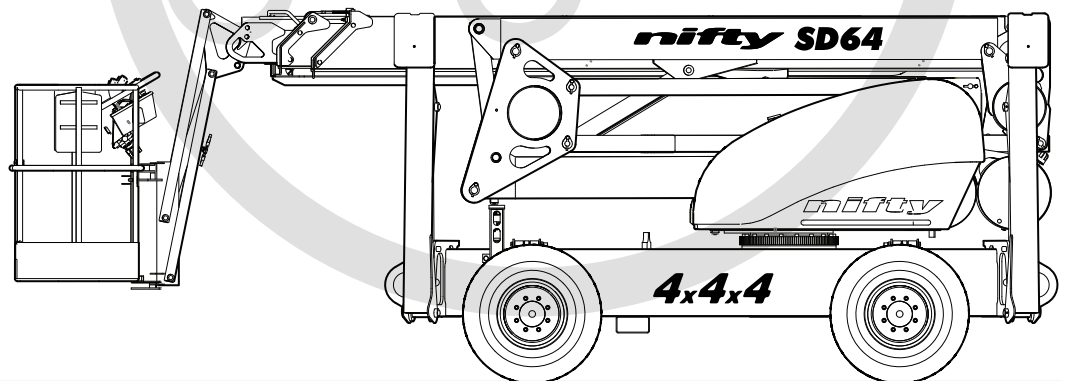

**niftylift.com**  
info@niftylift.com

M50907/02



#### Niftylift Limited

1525 S. Buncombe Road  
Greer  
SC 29651  
USA

www.niftylift.com  
e-mail: niftyusa@niftylift.com  
Tel: 864-968-8881  
Fax: 864-968-8836



# Table of Contents

<b>1</b>	<b>Introduction and General Information</b>	<b>2</b>
1.1	FOREWORD	2
1.2	SCOPE	3
1.3	INTRODUCING THE NIFTYLIFT SELF-DRIVE (SD) SERIES	3
1.4	GENERAL SPECIFICATION	4
1.5	IDENTIFICATION (USA PLATE)	6
<b>2</b>	<b>Safety</b>	<b>7</b>
2.1	MANDATORY PRECAUTIONS	7
2.2	ENVIRONMENTAL LIMITATIONS	10
2.3	NOISE AND VIBRATION	11
2.4	TEST REPORT	11
<b>3</b>	<b>Preparation and Inspection</b>	<b>12</b>
3.1	UNPACKING	12
3.2	PREPARATION FOR USE	12
3.3	PRE-OPERATIONAL SAFETY CHECK SCHEDULES	13
3.4	PLACARD, DECALS & INSTALLATION	15
3.5	TORQUE REQUIREMENTS	18
<b>4</b>	<b>Operation</b>	<b>19</b>
4.1	CONTROL CIRCUIT COMPONENTS	19
4.2	SETTING UP PROCEDURES	21
4.3	GROUND CONTROL OPERATION	22
4.4	BASKET CONTROL OPERATION	25
4.5	DRIVING CONTROLS	29
4.6	OUTRIGGERS	30
4.7	BASKET WEIGH SYSTEM (Optional)	31
4.8	TRANSPORTING, TOWING, CRANEAGE, STORAGE AND SETTING TO WORK	32
<b>5</b>	<b>Emergency Controls</b>	<b>35</b>
5.1	GENERAL	35
5.2	IN THE EVENT OF AN INCAPACITATED OPERATOR	35
5.3	IN THE EVENT OF MACHINE FAILURE	35
5.4	TOWING	37
5.5	INCIDENT NOTIFICATION	39
<b>6</b>	<b>Responsibilities</b>	<b>40</b>
6.1	CHANGES IN OWNERSHIP	40
6.2	MANUAL OF RESPONSIBILITIES	40
6.3	INSPECTION/SERVICE/PRE-HIRE CHECK LIST	41

# 1 Introduction and General Information

## 1.1 FOREWORD

The purpose of these manuals is to provide the customer with appropriate safety operating and maintenance instructions essential for proper machine operation.

All information in these manuals should be **READ** and fully **UNDERSTOOD** before any attempt is made to operate the machine. **THESE MANUALS ARE VERY IMPORTANT TOOLS** - Keep them with the machine at all times.

The manufacturer has no direct control over machine application and use, therefore conformance with good safety practices is the responsibility of the user and his operating personnel.

All information in these manuals is based on the use of the machine under proper operating conditions. Alteration and/or modification of the machine are strictly forbidden.

One of the most important facts to remember is that any equipment is only as safe as those who operate it.

### **DANGER, WARNING, CAUTION, IMPORTANT, INSTRUCTIONS AND NOTICE**

Any place these topics may appear, either in this manual or on the machine, are defined as follows:

**DANGER:** If not correctly followed there is a high probability of serious injury or death to personnel.

**WARNING OR CAUTION:** If not correctly followed there is some possibility of serious injury or death to personnel.



**THE 'SAFETY ALERT' SYMBOL IS USED TO CALL ATTENTION TO POTENTIAL HAZARDS THAT MAY LEAD TO SERIOUS INJURY OR DEATH, IF IGNORED.**

**IMPORTANT AND INSTRUCTIONS:** Denotes procedures essential to safe operation and prevention of damage to or destruction of the machine.

**NOTICE:** Indicates general safety rules and/or procedures relating to the machine.

It is the owner's/user's responsibility to know and comply with all applicable rules, regulations, laws, codes and any other requirements applicable to the safe use of this equipment.

## **1.2 SCOPE**

These operating instructions contain all the necessary information required to allow the safe operation of any Niftylift SD64 4x4x4, powered by a diesel (D) engine.

For further technical information, circuit diagrams and specific instructions for all maintenance which may need to be carried out by specialist trained personnel, see the associated Workshop and Parts manual for your model of Niftylift Self-Drive.

## **1.3 INTRODUCING THE NIFTYLIFT SELF-DRIVE (SD) SERIES**

Please note at the time of going to press all information, illustrations, details and descriptions contained herein are valid. Niftylift reserves the right to change, alter, modify or improve its products without any obligations to install them on previously manufactured machines.

If, after reading this manual you require further information, please do not hesitate to contact us at your nearest office.

**Niftylift Inc, 1525 S. Buncombe Road, Greer, SC 29651 USA**

Tel: **864 968 8881**

Fax: **864 968 8836**

Email: **niftyusa@niftylift.com**

Driven from the basket, the Niftylift SD64 4x4x4 is an extremely versatile articulated boom platform of unique and simple design. It is capable of placing two men and their tools up to a working height of 69ft 7in or an outreach (past outriggers) 32ft 2in.

High traction or ground sensitive pneumatic tires and powerful hydraulic wheel motors give unsurpassed performance with the option of fast drive speed when the booms are in the drive position. High drive isolation and audible alarms activated by a ten-degree tilt sensor help to prevent the operator from working on unsafe terrain whilst driving using the high-drive function.

The Niftylift SD64 4x4x4 provides a fast, safe, cost effective method of access, both inside and out, for a multitude of applications where overhead working is required .

This product conforms to ANSI/SAIA A92.20-2018.

*Models include the following:*

D: - DIESEL

**Operating & Safety Instructions****1.4 GENERAL SPECIFICATION**

<b>FEATURE</b>	<b>SD64 4x4x4</b>
MAXIMUM HEIGHT - WORKING	70ft 2in
MAXIMUM HEIGHT - BASKET	64ft
MAXIMUM HEIGHT – STOWED (Galaxy 33/1550-16.5 Tires)	7ft 3in
MAXIMUM HEIGHT – STOWED FOR TRANSPORTING (Galaxy 33/1550-16.5 Tires)	7ft 5in
MAXIMUM LENGTH - STOWED	21ft 2in
MAXIMUM LENGTH – STOWED FOR TRANSPORTING	17ft 11in
MAXIMUM OUTREACH – PAST OUTRIGGERS	35ft
MAXIMUM WIDTH – STOWED (Galaxy 33/1550-16.5 Tires)	6ft 7in
MAXIMUM CAPACITY	500lbs
TURRET TAIL SWING	0ft 0in
TRAVEL SPEED – LOW REVS	2.2mph
TRAVEL SPEED – HIGH REVS	4.7mph
BASKET SIZE – LENGTH x WIDTH	68in x 28in
GROUND CLEARANCE - DRIVING	12in
GROSS VEHICLE WEIGHT	9083lbs
TURRET ROTATION	355°
CONTROL SYSTEM	Fully Proportional Booms
HYDRAULIC PRESSURE – BOOMS	3336 psi
HYDRAULIC PRESSURE – DRIVE	5076 psi
TIRES – SIZE	Trelleborg 380/55-17
TIRES – PRESSURE	32 psi
MAXIMUM FLOOR LOAD ON ONE FOOT	7194 lbf
MAXIMUM PRESSURE ON ONE FOOT	7725 lb/ft <sup>2</sup>
MAXIMUM FLOOR PRESSURE/WHEEL @ 32 psi	3968 lb/ft <sup>2</sup>

---

***nifty* SD64 Series**  
**Operating & Safety Instructions**

<b>FEATURE</b>	<b>SD64 4x4x4</b>
GRADEABILITY	45% 24°
TRAVERSING SLOPE	17% 10°
FUEL TANK CAPACITY	21 US gallons
TURNING RADIUS (INSIDE) – 2 WHEEL STEER	11ft 10ins
TURNING RADIUS (INSIDE) – 4 WHEEL STEER	5ft 3ins
CONTROL SYSTEM VOLTAGE – MAXIMUM	12V
CURRENT – MAXIMUM	125A
PULL FORCE – MAXIMUM AT BASKET	400N 90lbf
MAXIMUM TILT ANGLE - BOOMS	0.5°
MAXIMUM TILT ANGLE - DRIVE	10°
ENGINE – KUBOTA V1505	18.5kW 24.8hp

**1.5 IDENTIFICATION (USA PLATE)**

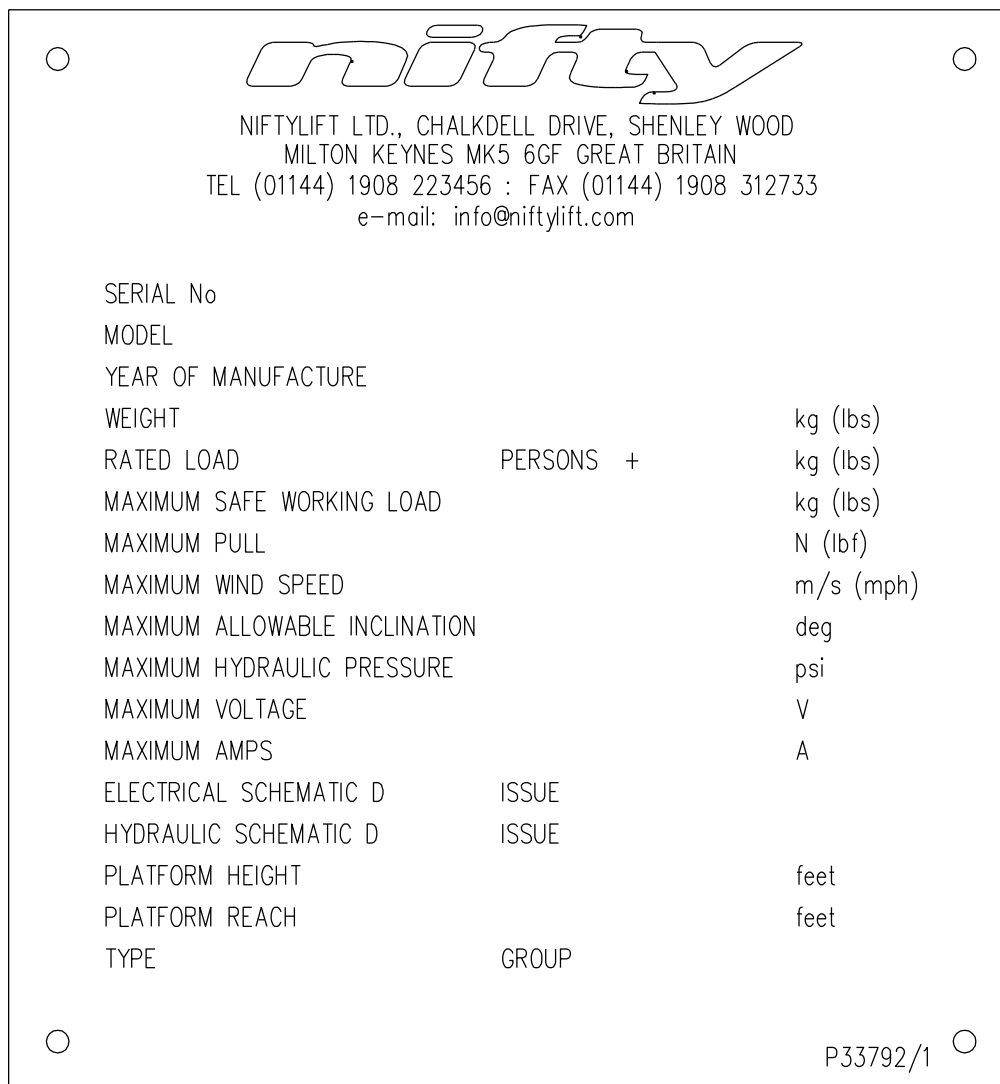

**This manufacturer's plate is attached to the Base on each machine at the time of manufacture on every Niftylift. Please ensure all sections have been stamped and are legible.**



## 2 Safety

### 2.1 MANDATORY PRECAUTIONS

When operating your Niftylift, your safety is of utmost concern. In order to fully appreciate all aspects of the machine's operation it should be ensured that each operator has **READ** and fully **UNDERSTOOD** the relevant manual covering machine use, maintenance and servicing. If any doubts exist concerning any points covered in your manual, contact your local dealer or Niftylift Ltd.

Before using any Niftylift, thoroughly inspect the machine for damage or deformation to all major components. Likewise, check the control systems for hydraulic leaks, damaged hoses, cable faults or loose covers to electrical components. At no time should damaged or faulty equipment be used - Correct all defects before putting the basket to work. If in doubt, contact your local dealer or Niftylift Ltd (see front cover for address).



**THE MANUFACTURER HAS NO DIRECT CONTROL OVER THE MACHINE APPLICATION AND USE. THEREFORE CONFORMANCE WITH GOOD SAFETY PRACTICES IS THE RESPONSIBILITY OF THE USER AND HIS OPERATING PERSONNEL. FAILURE TO UNDERSTAND AND FOLLOW ALL SAFETY RULES COULD RESULT IN SERIOUS INJURY OR DEATH.**

- 2.1.1** Only authorised persons trained on the same or a similar model will be permitted to operate the aerial Niftylift.
- 2.1.2** Always operate the Niftylift in full accordance with the manufacturer's Operating & Safety Instructions for that model.
- 2.1.3** Before use each day and at the beginning of each shift the Niftylift shall be given a visual inspection and functional test including, but not limited to, operating and emergency controls, safety devices, personal protective clothing, including fall protection, air, hydraulic and fuel system leaks, cables and wiring harness, loose or missing parts, tires and wheels, placards, warnings, control markings and Operating and Safety Manuals, guards and guard rail systems and all other items specified by the manufacturer.
- 2.1.4** Any problems or malfunctions that affect operational safety must be repaired prior to use of the basket, with specific regard to any safety components refer to the Parts Manual for part numbers and details. If in doubt, contact Niftylift Ltd (Details on page 3).
- 2.1.5** Always ensure that all warning labels, instructions, placards, control markings and Safety Manuals are intact and clearly legible. If replacements are required contact your local dealer or Niftylift. Always observe and obey safety and operating instructions on such labels.
- 2.1.6** Do not alter, modify or disable in any way the controls, safety devices, interlocks or any other part of the machine.
- 2.1.7** Before the Niftylift is used and during use the user shall check the area in which it is to be used for possible hazards such as, but not limited to, uneven ground drop-offs, holes, bumps, obstructions, debris, floor and overhead obstructions, high voltage conductors, wind and weather, unauthorised persons and any other possibly hazardous conditions.
- 2.1.8** Never exceed the maximum basket capacity, as indicated on the decals and machine serial plate.

**Operating & Safety Instructions**

- 2.1.9** Never position any part of the Niftylift within the Minimum Approach Distances of any electrical power line, conductor, or similar stated in Occupational Safety and Health Administration Regulations for CFR 1910.333(c) for Minimum Approach Distance for electrical wires.
- 1910.333(c)(3)(i)(A)(1): For voltages to ground **50kV or below** - 10 feet (305 cm);
- 1910.333(c)(3)(i)(A)(2): For voltages to ground **over 50kV** - 10 feet (305 cm) plus 4 inches (10 cm) for every 10kV over 50kV.



**THIS MACHINE IS NOT INSULATED.**

If in doubt, contact the appropriate authorities.

- 2.1.10** On entering the basket ensure that the sliding midrail is fully down in its correct “closed” position.
- 2.1.11** Use of an approved safety belt and lanyard, hardhat and appropriate safety clothing is strongly recommended for operator safety. Fasten harness to designated harness securing points within the basket and do not remove until leaving the basket whilst in the stowed position.



Always remain standing within the basket. Do not attempt to increase your height or reach by standing and/or climbing on the basket guardrails or any other object. **KEEP YOUR FEET ON THE BASKET FLOOR.** Do not sit, stand or climb on the guardrail, mid rail or boom linkage. Use of planks, ladders or any other devices on the Niftylift for achieving additional height or reach is prohibited.

- 2.1.12** Do not use the basket levelling system to artificially increase the outreach of the Niftylift. Never use boards or ladders in the basket to achieve the same result.
- 2.1.13** Do not use the basket to lift overhanging or bulky items that may exceed the maximum capacity or carry objects that may increase the wind loading on the Niftylift. (e.g. Notice boards etc.)
- 2.1.14** The Niftylift shall not be operated from a position on trucks, trailers, railway cars, floating vessels, scaffolds or similar equipment unless Niftylift Ltd in Great Britain approves the application in writing.
- 2.1.15** Always check below and around the basket before lowering or rotating the booms to ensure that the area is clear of personnel and obstructions. Care should be taken when rotating the booms out into areas where there may be passing traffic. Use barriers to control traffic flow or prevent access to the machine.
- 2.1.16** Stunt driving or horseplay, on or around the Niftylift, shall not be permitted.
- 2.1.17** When other moving equipment and vehicles are present, special precautions shall be taken to comply with local ordinances or safety standards established for the work place. Warnings such as, but not limited to, flags, roped off areas, flashing lights and barricades shall be used.
- 2.1.18** Under all travel conditions the operator shall limit travel speed according to conditions of ground surface, congestion, visibility, slope, location of personnel and other factors causing hazards of collision or injury to personnel.
- 2.1.19** The Niftylift shall not be driven on grades, side slopes or ramps exceeding those for which the manufacturer rates the aerial basket.
- 2.1.20** The aerial platform is not equipped for or intended for use on a public highway.

- 2.1.21** It shall be the responsibility of the user to determine the hazard classification of any particular atmosphere or location. Aerial platforms operated in hazardous locations shall be approved and of the type required. (For the USA refer to ANSI/NFPA 505)
- 2.1.22** The operator shall immediately report to his supervisor any potentially hazardous location(s) (environment) which become evident during operation.
- 2.1.23** If an operator encounters any suspected malfunction of the Niftylift or any hazard or potentially unsafe condition relating to capacity, intended use or safe operation he shall cease operation of the Niftylift and request further information as to safe operation from his management, or owner, dealer or manufacturer before further operation of the Niftylift.
- 2.1.24** The operator shall immediately report to his superior any problems or malfunctions of the Niftylift, which becomes evident during operation. Any problems or malfunctions that affect the safety of operation shall be repaired prior to continued use.
- 2.1.25** The boom and basket of the Niftylift shall not be used to jack the wheels off the ground.
- 2.1.26** The Niftylift shall not be used as a crane.
- 2.1.27** The Niftylift shall not be positioned against another object to steady the basket.
- 2.1.28** Care should be taken to prevent rope, electric cords and hoses from becoming entangled in the Niftylift.
- 2.1.29** Batteries shall be recharged in a well-ventilated area free of flame, sparks or other hazards (e.g. do not smoke near the machine) that may cause explosion. Highly explosive hydrogen gas is produced during the charging process.
- 2.1.30** When checking electrolyte levels great care should be taken to protect eyes, skin and clothing. Battery acid is highly corrosive and protective glasses and clothing is recommended.
- 2.1.31** When the machine is not in use always stow the booms correctly. **NEVER LEAVE THE KEYS IN THE MACHINE**, if it is to be left for any period of time. Use wheel chocks if leaving on an incline.
- 2.1.32** If the basket or elevating assembly becomes caught, snagged or otherwise prevented from normal motion by adjacent structure or other obstacles, such that control reversal does not free the basket, all personnel shall be removed from the basket safely before attempts are made to free the basket using ground controls.
- 2.1.33** The engine must be shut down while fuel tanks are being filled. Fuelling must be done in a well-ventilated area free of flame, sparks or any other hazard that may cause fire or explosion. **GASOLINE LIQUID PROPANE AND DIESEL FUELS ARE FLAMMABLE.**



**NEVER START THE NIFTYLIFT IF YOU SMELL GASOLINE, LIQUID PROPANE OR DIESEL FUEL. THESE FUELS ARE HIGHLY FLAMMABLE.**

- 2.1.34** The operator must ensure that engine powered machines are used in a well-ventilated area to minimise the risk of carbon monoxide poisoning.
- 2.1.35** The operator shall implement means provided to protect against use by unauthorised persons.
- 2.1.36** Never remove anything that may affect the stability of the machine such as, but not limited to, batteries, covers, engines, tires or ballast.

## Operating & Safety Instructions

- 2.1.37** The operator must ensure that the controls are not obstructed (e.g. by tools or equipment) and **clear access to the Emergency Stop** is available at all times.
- 2.1.38** All persons in the basket must take suitable precautions to prevent items falling or being ejected from the basket. E.g. Tethering tools to the machine or operator if practical and an assessment of any resulting risks is acceptable.
- 2.1.39** Hydraulic oil escaping under pressure can penetrate the skin and cause **serious injury**. Do not allow hydraulic oil to squirt or spray. **Seek immediate medical attention in the event of hydraulic oil penetrating the skin.** Wear chemical-resistant protective gloves and suitable eye protection when handling hydraulic oil. Relieve system pressure before removing any hydraulic connections, undo fittings slowly to make sure there is no residual pressure. If pressure is detected, allow it to be released slowly before completely removing hose. Fluid leaks may not be visible to the naked eye. Use a piece of cardboard to check for leaks, not your hand. Never install hydraulic lines or components that are damaged.
- 2.1.40** Only Niftylift original and supplied parts shall be used. Replacement of parts should only be carried out by appropriately trained and competent persons.

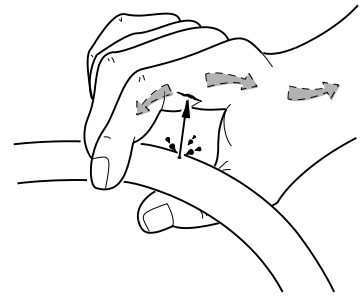

## 2.2 ENVIRONMENTAL LIMITATIONS

Unless specifically configured otherwise, the machine will have a short operational time in extreme temperatures such as freezers and cold storage, due to reduced battery performance. For electrical cables and components, the temperature must be within the range  $-5^{\circ}\text{C}$  to  $60^{\circ}\text{C}$ .

The machine is limited in high temperatures because of the cooling requirement for engines and hydraulic oil. Coolant temperatures must be within the range  $-37^{\circ}\text{C}$  to  $110^{\circ}\text{C}$  (at 50% mixture of water to anti-freeze). Oil temperature is not to exceed  $-23^{\circ}\text{C}$  to  $93^{\circ}\text{C}$ .

**The recommended operational range for these machines is  $-5^{\circ}\text{C}$  to  $+30^{\circ}\text{C}$ . Please contact Niftylift Ltd for special considerations if the machine is required to operate outside these temperatures.**

Extended operation in dusty environments is not recommended and frequent cleaning will be necessary. All dust, dirt, salt encrustation, excess oil or grease should be removed. Deposits of paint or bitumen, particularly on legends or labels should also be removed.

All standard Niftylift machines are rated for a wind speed of 28mph or force 6 on the Beaufort scale. No attempt should be made to operate a Niftylift in wind strengths above this limit and if the operator has any doubts over the wind speed he / she should cease operation immediately until it can be established that the wind speed has fallen to a safe level.



**DO NOT USE THE NIFTYLIFT IN ELECTRICAL STORMS.**

## 2.3 NOISE AND VIBRATION

The airborne noise emission on the Self-drive range of machines does not exceed 104dB(A), measured at a perpendicular distance of 10m, under equivalent continuous A-weighted sound pressure test conditions. This was based on a Diesel powered machine, working under load. All other models will exhibit significantly lower emissions than this figure, dependant on power option.

In normal operation the Vibration level to which the operator is subjected will not exceed a weighted root mean square acceleration value of 2.5 m/s<sup>2</sup>.

## 2.4 TEST REPORT

All Niftylift machine models are subjected to a comprehensive 'type test' which duplicates all combinations of safe working load (SWL), overload, windage, inertia and pull force to assess the various safe stability criteria. Self propelled machines are also subjected to kerb and braking tests at the SWL to satisfy additional 'worse case' stability requirements.

Each individual machine is then subjected to static overload tests on flat level ground with 150% of the SWL, exceeding the requirements of ANSI A92.20 for power operated MEWPs. Self propelled machines are also tested at the maximum working angle **plus** 0.5° with a test load of 125% of the SWL. Finally, on all machines, a functional test is performed with 110% of SWL.

All safety devices are checked for correct operation, operating speeds are checked against benchmark figures and the dynamic functions ensure that all acceleration and deceleration forces are within acceptable limits. All noted defects are rectified and recorded before the machine is permitted to enter into service.

## 2.5 ELECTRICAL SAFETY

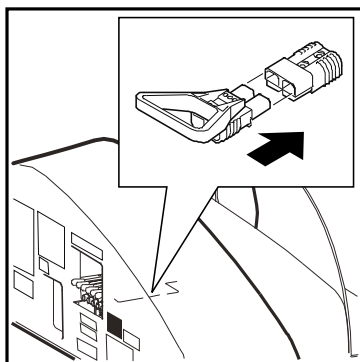

Machines are electrically isolated prior to shipment and require reconnection before use as shown.

## **3 Preparation and Inspection**

### **3.1 UNPACKING**

Since the manufacturer has no direct control over the shipping or carriage of any Niftylift it is the responsibility of the dealer and/or owner and/or leaser to ensure the Niftylift has not been damaged in transit and a Pre-operational Report has been carried out by a qualified engineer before the aerial basket is put into service.

- 1) Remove all ropes, straps and or chains used to secure the aerial basket during transit.
- 2) Ensure any ramp, loading dock or forklift used is capable of supporting or lifting the aerial basket.
- 3) If the Niftylift is to be driven off, please ensure that the operator has read and fully understood this entire manual. Refer to the appropriate section for precise operating instructions.

**\*\*\*Carry out the Pre-operational Report before placing machine in service.**

### **3.2 PREPARATION FOR USE**



Whilst every effort has been made at the Niftylift factory to ensure your machine arrives in a safe and operable condition it is necessary to carry out a systematic inspection prior to putting the Niftylift into service.

**THIS IS NOT A REQUEST IT IS MANDATORY.**

To assist the user in this task you will find enclosed an Inspection Check List (see section 6.3), which must be filled out upon delivery/receipt of the machine.

Before the user carries out the Inspection Check List he must have read and fully understood all the contents of the Operating, Safety and Maintenance Manual.



**WARNING - DO NOT OPERATE A POTENTIALLY DEFECTIVE OR MALFUNCTIONING MACHINE. CORRECT AND REPAIR ANY DEFECTS BEFORE OPERATING YOUR NIFTYLIFT.**

### **3.3 PRE-OPERATIONAL SAFETY CHECK SCHEDULES**

Before use at the beginning of the work shift, the Niftylift shall be given a visual inspection and functional tests including, but not limited to the following. It is recommended that these be performed at regular intervals as indicated on each checklist.

#### **3.3.1 DAILY SAFETY CHECKS**

- 1) Check that all labels (decals) are in place and legible.
- 2) Visually inspect the machine for damaged or loose components.
- 3) If fitted, check that batteries are charged (if applicable) i.e. Charger has a solid green light and a pulsing red light.
- 4) Check the fuel level (if applicable).
- 5) Check that canopies/covers and guards are in place and secure.
- 6) Check that the boom rest switch is operable.
- 7) Check that control levers are secure and operate freely.
- 8) Check that operating buttons and emergency stop buttons function properly.
- 9) Check the operation of the emergency hand pump.
- 10) Visually inspect all hydraulic hoses and fittings for damage or leaks.
- 11) Check operation of the outrigger alarm.
- 12) Check that outrigger footpads are secure.
- 13) Check that the basket pivot pins and their swing bolts are secure.
- 14) Check that SiOPS is functioning correctly (Refer to Section 4.4.2).
- 15) Check the operation of the basket weigh system (If fitted). See section 4.7.3 for testing and verification procedure.

#### **3.3.2 WEEKLY SAFETY CHECKS**

- 1) Inspect tires and wheels for damage and wear.
- 2) Check tires for correct pressure. 32 psi (2.2 bar)
- 3) Check suspension and dampers for damage and leaks.
- 4) Check that the joystick is secure.
- 5) Check battery fluid levels and specific gravity (after charging) and general condition.
- 6) Check hydraulic oil level, Grade 46.
- 7) Inspect the engine air filter and clean or replace if necessary.
- 8) Check operation and security of outrigger micro switches in conjunction with the alarm system.
- 9) Inspect hose track for damage or missing parts.

## Operating & Safety Instructions

### 3.3.3 MONTHLY SAFETY CHECKS

- 1) Check the engine oil level (if applicable).
- 2) Check the wheel bolts (torque 110ft lbs / 150Nm).
- 3) Check that the bolts holding the wheel motors to the chassis are secure.
- 4) Check outriggers for condition, security and operation.
- 5) Check that the rotation gear worm is secure and correctly in mesh. Clean and re-grease.
- 6) Grease the rotation gear and worm gear.
- 7) Inspect the engine fuel tank for damage or leaks.
- 8) Check telescopic boom wear pads and nylon studs (if applicable).
- 9) Check and adjust if necessary the Nylatron studs around the telescope boom.
- 10) **If fitted**, every **three** months check and verify the calibration of the basket weigh system. See section 4.7.4 for the calibration procedure.
- 11) Every **Six** months perform a **thorough examination** in accordance with the 'Lifting Operation and Lifting Equipment Regulations' (LOLER) 1998, Regulation (9)(3)(a).

### 3.3.4 ANNUAL SAFETY CHECKS

- 1) Check that all pivot pins and their swing bolts are secure.
- 2) Inspect for any cracks or badly rusted areas on booms and chassis.
- 3) Change the hydraulic oil and the oil filters.
- 4) Check the bushes in the front wheel hubs for wear.
- 5) Check that ringbolts are secured (torque 218ft lbs. / 295Nm).



**3.4 PLACARD, DECALS & INSTALLATION**

<b>ITEM</b>	<b>DESCRIPTION</b>	<b>NUMBER</b>	<b>QTY</b>
1	No Step	P14785	6
2	E-Stop Warning	P14864	2
3	Footswitch	P14884	1
4	Cage Control Panel	P23666	1
5	Hydraulic Controls – 6 Levers	P14020	1
6	If Tilt Alarm Sounds	P18842	2
7	Overload Warning	P18848	2
9	Nifty SD64 - Grey	P19421	2
10	Hazard Tape		A/R
11	Niftylift.Com	P14390	2
12	'1,2,3,4' Grey	P17000	1
13	General Warning	P24900	2
14	Tie Down Points	P17556	4
15	Outriggers Warning	P14841	4
16	Base Controls	P16752	1
17	Hydraulic Controls – 6 Levers	P22042	2
18	Booms/Drive Selector	P23093	1
19	4x4x4 - Grey	P17437	2
20	Daily Safety Check List	P14908	1
21	Battery - Isolator	P18600	1
22	Battery Drain	P19850	1
23	Travel Directions	P14784	1
24	Hydraulic Oil	P17227	1
25	Trip – Push To Reset	P19056	1
26	Electric Luffing/Levelling	P17559	1
27	Read Manual	P14892	1
28	Harness Points	P32302	2
29	Swl 225 Kg	P17328	1
30	General Crush	P14782	11
31	Diesel	P14414	1
32	Jack Point	P17557	4
33	10 Degree Lateral Tilt	P21049	1
34	Oil Level	P14676	1
35	Point Load – 25 kN	P17558	4
36	Serial Plate	P15383	1
37	Cage Gate Warning	P18335	1
38	Manual Descent	P19605	1

## **nifty** SD64 Series

### **Operating & Safety Instructions**

---

39	Chain Inspection		P16535	1
40	Noise Warning		P34374	1
41	Outrigger Controls		P19192	1
42	General Notice		P21941	1
43	Hot surfaces/Moving machinery		P22314	1
44	Cage Tie-Down Warning		P21404	2
45	Rotating Machinery (USA)		P15010	2
46	Gearbox Disengage	Type 1	P18811	4
		Type 2	P19180	4
47	SiOPS Instructions		P22820	1
48	Horn		P23739	1
49	Pressurised Tank		P16365	1
50	Clunk Click		P19961	2
51	IPAF Are you trained?		P22055	1
52	Emergency Controls Location		P22877	1
54	Emergency Controls Location		P21700	1
56	Objects on Controls		P21511	1
57	Power to cage socket	110V	P26426	1
58	Power to cage (Tool)	110V	P33012	1
59	Compliance statement (USA)		P25250	1



**Operating & Safety Instructions**

**3.5 TORQUE REQUIREMENTS**

BOLT QUALITY/SIZE	Tightening torque in lbs ft (Nm)					
	Plated			Unplated		
Grade	8.8	10.9	12.9	8.8	10.9	12.9
M 6	5 (7)	8 (10)	9 (12)	6 (8)	8 (11)	10 (13)
M 8	13 (17)	18 (25)	22 (29)	14 (19)	20 (27)	23 (32)
M 10	25 (34)	36 (49)	43 (58)	27 (37)	40 (54)	46 (63)
M 12	43 (58)	63 (85)	73 (99)	47 (63)	69 (93)	80 (108)
M 14	68 (93)	100 (135)	117 (158)	74 (101)	109 (148)	127 (172)
M 16	106 (143)	154 (209)	180 (245)	115 (156)	168 (228)	197 (267)
M 20	212 (288)	301 (408)	352 (477)	224 (304)	328 (445)	384 (521)
M24	362 (491)	515 (698)	602 (806)	383 (519)	561 (760)	656 (889)
WHEEL BOLTS	110 ft lbs (150 Nm)					
SLEW RING BOLTS	218 ft lbs (295 Nm)					

This torque chart is based on the following assumptions:

- 1) Bolts to ISO 898-1 "Mechanical properties of fasteners made of carbon steel and alloy steel"
- 2) For "unplated" bolts, all grades:
  - Hex head bolts
  - Black oxide steel bolt with a rolled & oiled thread, no finish on steel nut
  - Prevailing torque includes Nylock (minimum prevailing torque figure assumed)
  - Medium Clearance holes to ISO 273
  - Bolt tightening condition = Yield factor of 75%
- 3) For "plated" bolts, all grades:
  - Hex head bolts
  - Zinc plated oiled (rolled or cut) steel external thread with no finish on steel internal thread
  - Prevailing torque includes Nylock (minimum prevailing torque figure assumed)
  - Medium Clearance holes to ISO 273
  - Bolt tightening condition = Yield factor of 75%

Figures quoted in **Nm** have been calculated in Nm and then rounded to the nearest whole number. Figures quoted in **lb-ft** have been calculated in Nm, converted using a factor of 0.737561 and then rounded.

## 4 Operation

### 4.1 CONTROL CIRCUIT COMPONENTS

**4.1.1 MAIN CONTROL BOARD:** - Situated under the left-hand superstructure cover, the encapsulated control board comprises a PCB (printed circuit board) design that incorporates all of the circuit to control the machine operation. The control boards are common to all models, and contain functions that might not be utilised on your particular machine.

**4.1.2 BASKET OVERLOAD:** **If the** Niftylift is fitted with a basket overload sensing device located between the basket bracket and the basket itself. This device is preset at the factory and must only be reset or adjusted by a qualified Niftylift representative. If the basket payload of 500lbs is exceeded, the sensor will immediately shut off the diesel engine preventing further use of the machine. The diesel engine cannot be restarted until the payload is reduced to a mass of 500lbs or less.

**4.1.3 TILT ALARM:** - There is a 10° tilt alarm fitted to the superstructure underneath the base controls cover, which is a solid-state sensor that monitors the inclination of the machine. This tilt alarm operates a sounder and warning lamp on the basket control panel warning the operator that the machine is operating on a slope greater than or equal to 10°. **Great care must be taken at all times when manoeuvring any machine on slopes greater than 10°.** If in any doubt as to the stability of the machine whilst operating across a slope partially deploy the downhill outriggers for additional safety.



**WARNING – Continuing to drive across slopes in excess of a 10° inclination with the tilt sensor activated could result in the machine rolling over causing serious injury or death!**

**4.1.4 SOUNDER:** - Situated on the front of the base control box is a small piezo electric sounder, which is used to provide an intermittent alarm whenever the machine is in operation. Pushing the green "power control" button, or depressing the foot switch in the basket (if fitted) will energise this sounder. This serves to warn personnel of the operation of the machine.

**4.1.5 HORN:** - Located on the side of the base control box is a horn, which is used as a manual alert, by pushing the "Horn" button at the Basket control position.

**4.1.6 SIREN:** - Also located on the side of the base control box is a device that sounds continuously if the Tilt Alarm Sensor detects excessive inclination when the allowable ground slope is exceeded while driving.

It will also sound when the low fuel warning light comes on.

Lastly it will sound when any of the stabiliser feet lifts free from the ground.

**4.1.7 MAIN CONTROL VALVE:** - The main control valve contains the steer valve and the brake release system. Should any of these functions require overriding, use the hand pump, (see Section 5.3).

**4.1.8 BOOM CONTROL VALVE:** - The boom control valve contains the ON/OFF solenoid and PRV for the boom controls. Should any of these functions require overriding, use the hand pump, (see Section 5.3).

**4.1.9 BOOM-SWITCHES:** - Mounted on the tele-knuckle and the booms down/centralising post located on the top of the base, and operated by any of the booms raising and/or the telescopic boom extending, these switches control both the operation of the Tilt Alarm Sensor, and the drive speed control function.

## Operating & Safety Instructions

With the booms in the stowed position, the operator is allowed to drive the machine and negotiate slopes up to 10° without activating the tilt alarm (Refer to 4.1.3).

Because of the restricted visibility over the engine canopy, an electric luffing switch has been provided. Using this switch on the basket console permits the operator to elevate the luffing boom to a restricted safe height for driving the machine thus providing better visibility.

Before elevating the booms, the operator must first deploy and set up each of the outriggers using the switches on the basket console until the base is level. The level of the machine can be checked using the spirit level located on top of the base. To ensure that all of the stabiliser feet are correctly deployed, check that the light on each of the stabiliser switches has turned off.

Once the outriggers are correctly set up, the operator can use all boom functions. Should an outrigger foot come clear of the ground, an audible siren will sound as well as a flashing warning light on the basket console. Also the light on the switch that controls that particular outrigger will light up again indicating which one has gone light. If this happens, return all booms to their stowed position. This will return control to the outriggers allowing them to be reset.

**4.1.10 BATTERY MANAGEMENT:** - Under no circumstances should a machine be left fully discharged or severe battery damage can occur in a relatively short time.

**4.1.11 BATTERY ISOLATOR:** - A battery disconnect plug is located beneath the base control canopy, which allows the machine control and power circuits to be isolated from the batteries themselves. Under normal operation, the machine Key Switch should be used to isolate the machine, with the Battery Isolator plug only being required for emergencies to disconnect the batteries in the event of a short circuit, or during servicing of the machine to ensure that the power is disconnected. The battery is grounded to the chassis.

**4.1.12 DIESEL ENGINE:** -

- 1) **125A** fuse near the diesel engine battery (starter motor and alternator).
- 2) **10A** circuit breaker - (main control system).
- 3) **35A** circuit breaker - (heavy-duty circuit for diesel throttle/Glow plug).
- 4) **15A** circuit breaker – (all solenoid functions).

**4.1.13 LOAD SENSING CONSOLE (SiOPS™):** - This machine incorporates a load sensing cage console that senses if the operator has been pushed or has fallen against the console. If the load applied to the front of the console is greater than the pre-determined amount, the footswitch will be disabled to increase operator safety and reduce the possibility of sustained involuntary operation of the cage controls. For further information refer to Section 4.4.2.

## 4.2 SETTING UP PROCEDURES



**FAILURE TO DEPLOY THE OUTRIGGERS CORRECTLY COULD RESULT IN DEATH OR SERIOUS INJURY.**

### ALL MODELS

- 1) Read and fully comply with all safety precautions and operating instructions in the Operating and Safety manual and the warning decals on the machine.
- 2) Position Niftylift on firm ground, bearing in mind range of boom movement so that any overhead obstructions or possible hazards such as, but not limited to, power cables, telephone lines, drains, manhole covers, etc. can be safely avoided
- 3) If the load bearing capacity of the ground is in any doubt the machine must **NOT** be used.
- 4) Levelling the machine using the hydraulic outriggers can accommodate a slope of up to 12 degrees, if necessary using suitable load bearing pads to support the downhill jacks. Do not elevate the platform unless the base can be corrected to within 0.5 degrees of level.
- 5) Chock wheels and cordon off area using appropriate cones, barriers and flags.
- 6) Check all red emergency stops are not engaged i.e. fully out.
- 7) Ensure Base/Basket selector is turned up to basket position.
- 8) From the basket control station depress the footswitch to give hydraulic power to the outriggers. Note: No power will be available if the booms are not stowed onto the boom rest.
- 9) Using the four outrigger control switches, lower each outrigger onto a firm, level surface and level machine base ensuring each outrigger foot is taking equal weight with the wheels clear off the ground. Each switch has a light that will turn off once the outrigger foot has been correctly deployed.
- 10) Check machine is level using spirit level on the base, visible from the basket.
- 11) The booms can now be operated from the basket control station by depressing the footswitch. Note: If no power is available check each outrigger is lowered and each footpad is taking equal weight.
- 12) Always lower booms fully before adjusting, raising, retracting or moving the outriggers in any way.
- 13) Never alter, modify or block any of the safety circuits on the Niftylift.



**THIS MACHINE IS NOT ELECTRICALLY INSULATED. DO NOT WORK WITHIN 10FT OF OVERHEAD CABLES EXCEEDING 415 VOLTS**

### 4.3 GROUND CONTROL OPERATION



**ALWAYS ALLOW THE ENGINE TO WARM UP BEFORE OPERATION.**

#### 4.3.1 GROUND CONTROL INSTRUCTIONS

##### ALL MODELS

- 1) Check below, above and around the basket for any obstructions or hazards before operating any function.
- 2) Ensure all red emergency stops are out.
- 3) Turn **Base/Basket** selector at ground control station to **Ground** (Clockwise).

##### DIESEL ENGINE

- 4) For a cold engine start go to step 5) or for a warm engine start go to step 6).
- 5) **COLD ENGINE:** - turn the **Diesel Glow/Start** selector to the **Glow** position (anti-clockwise). This engages the glow plug pre-heat system. Hold for 3-5 seconds then turn the key to the **Start** position (fully clockwise) and the engine will fire. If the engine doesn't fire, then repeat this step
- 6) **WARM ENGINE:** - turn the **Diesel Glow/Start** selector to the **Start** position (clockwise) and the engine will fire.

##### ALL MODELS

- 7) Push and hold green power button.
- 8) Select the boom function required and operate hand levers in full accordance with manufacturer's Operating and Safety manual.
- 9) To change control to the basket turn the **Base/Basket** selector to the **Basket** position (anti-clockwise).
- 10) When not in use return machine to stowed position. **Note:** Fully lower the Link booms first (Lever 4) followed by the Upper boom (Lever 5) for smooth operation. Fully raise and stow all outriggers, turn the **Base/Basket** selector to the centre "**OFF**" position, remove key and chock wheels.

##### EMERGENCY PROCEDURES

- 11) Push in red emergency stop to shut down all functions.
- 12) Use emergency hand pump (located under control canopy) to provide motive power and manoeuvre the machine as normal using the hand levers (Basket or Base).



**BASE CONTROL STATION**

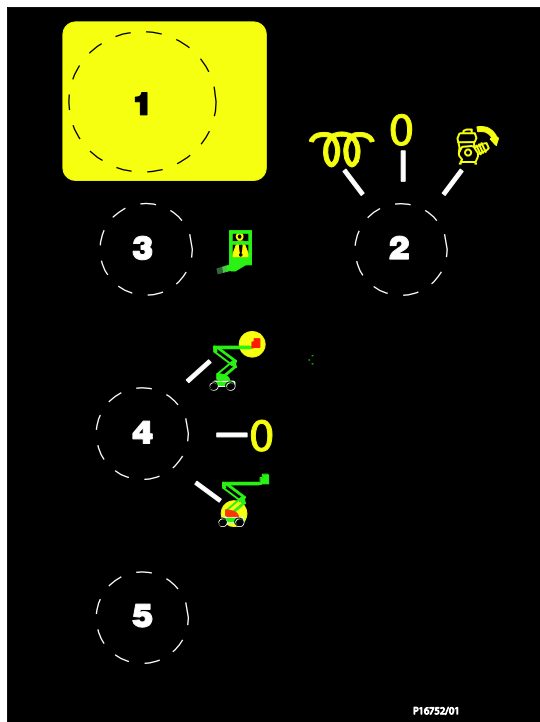

<b>1</b> Emergency Stop	<b>PUSH</b> to stop machine	TURN CLOCKWISE to release
<b>2</b> Diesel Glow/Start Selector	<b>TURN ANTI-CLOCKWISE</b> – Glow; Release or Off <b>TURN CLOCKWISE</b> – Start positions	
<b>3</b> Basket Overload Alarm	<b>Light ON</b> – Payload in basket exceeds 225kg	
<b>4</b> Base/Basket Selector	<b>UP</b> for Basket Controls	<b>DOWN</b> for Base Controls
<b>5</b> Green Power button	<b>PUSH</b> and hold to energise machine	

**BOOM FUNCTIONS**

- 1) Push and hold green power button.

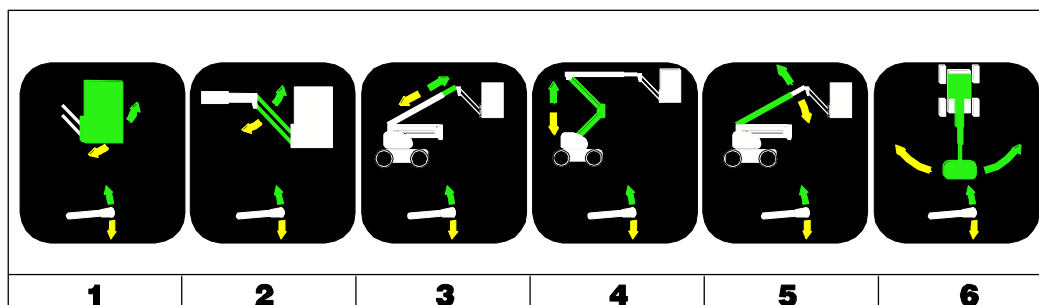

**Operating & Safety Instructions**

---

2) Select lever 1, 2, 3, 4, 5 or 6 for desired boom function.

<b>1</b> Operates Basket levelling	<b>UP</b> for backwards	<b>DOWN</b> for forward
<b>2</b> Operates Flyboom	<b>UP</b> for up	<b>DOWN</b> for down
<b>3</b> Operates Telescoping	<b>UP</b> for out	<b>DOWN</b> for in
<b>4</b> Operates Links	<b>UP</b> for up	<b>DOWN</b> for down
<b>5</b> Operates Luffing boom	<b>UP</b> for up	<b>DOWN</b> for down
<b>6</b> Operates Boon Rotation	<b>UP</b> for right	<b>DOWN</b> for left



**ALWAYS ENSURE THE AERIAL BASKET IS ON A FIRM SURFACE AND THE AREA IS FREE OF ANY OVERHEAD OBSTRUCTIONS.**

**ENGAGING THE RED EMERGENCY STOP BUTTON WILL SHUT DOWN THE ENGINE AND THE ELECTRIC CIRCUIT PREVENTING OPERATION OF ANY FUNCTION.**

## 4.4 BASKET CONTROL OPERATION



**NEVER START THE NIFTYLIFT IF YOU SMELL GASOLINE, LIQUID PROPANE OR DIESEL. THESE FUELS ARE FLAMMABLE.**

**BEFORE OPERATING THE NIFTYLIFT ENSURE THAT EACH OPERATOR HAS READ AND FULLY UNDERSTOOD THE OPERATING MANUAL. FAILURE TO DO SO MAY RESULT IN DEATH OR SERIOUS INJURY.**

**\*\*\*FOR COLD START PROCEDURES SEE SECTION 4.4.1\*\*\***

**ALWAYS ALLOW THE ENGINE TO WARM UP BEFORE OPERATING.**

### 4.4.1 BASKET CONTROL INSTRUCTIONS

#### ALL MODELS

- 1) **NEVER** exceed the maximum basket capacity.
- 2) Check below, above and around the basket for any obstruction or hazards before operating any function.
- 3) Ensure all red emergency stops are out.
- 4) Turn **Base/Basket** selector at ground control station to **Basket** (Anti-clockwise).
- 5) Turn selector switch (2) on basket controls to **I** (clockwise).

#### DIESEL ENGINE

- 6) For a cold engine start go to step 7) or for a warm engine start go to step 8).
- 7) **COLD ENGINE:** - turn the **Diesel Glow/Start** selector to the **glow** position (anti-clockwise). This engages the glow plug pre-heat system. Hold for 3-5 seconds then turn the **key** to the **Start** position (fully clockwise) and the engine will fire. If the engine doesn't fire, then repeat this step.
- 8) **WARM ENGINE:** - turn the **On/Off Diesel Start** selector to the **Start** position (clockwise) and the engine will fire.

#### ALL MODELS

- 9) Depress the footswitch.
- 10) Select the boom function required and operate hand levers in full accordance with manufacturer's Operating and Safety manual.
- 11) To change control to the base turn the **Base/Basket** selector to the **base** position (clockwise).
- 12) When not in use return machine to stowed position. **Note:** Fully lower the Link booms first (Lever 4) followed by the Upper boom (Lever 5) for smooth operation. Fully raise and stow all outriggers, turn the **Base/Basket** selector to the centre "**OFF**" position, remove key and chock wheels.

#### EMERGENCY PROCEDURES

- 1) Push in red emergency stop to shut down all functions.
- 2) Use emergency hand pump (located under control canopy) to provide motive power and manoeuvre the machine as normal using the hand levers (Basket or Base).

**nifty** SD64 Series  
**Operating & Safety Instructions**

**BASKET CONTROL STATION**

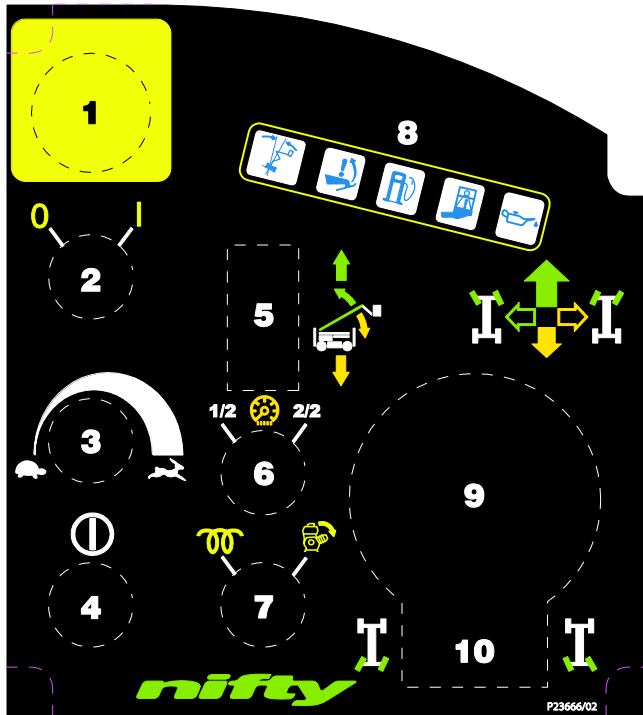

<b>1</b> Emergency Stop	<b>Push</b> to Stop machine	Turn clockwise to release
<b>2</b> Cage enable	<b>Left</b> = OFF	<b>Right</b> = ON
<b>3</b> Variable Speed Control	<b>Clockwise</b> increases speed	<b>Anti-clockwise</b> decreases speed
<b>4</b> Green Power Button	<b>Push</b> to energise machine	
<b>5</b> Electric Luffing	<b>UP</b> to elevate luffing boom	<b>DOWN</b> to lower luffing boom
<b>6</b> Hi/Low Engine Speed	<b>Left</b> = Low Revs	<b>Right</b> = High Revs
<b>7</b> Diesel Glow/Engine Start	<b>Left</b> = Engine Glow	<b>Right</b> = Engine Start
<b>8</b> Warning LED's	Tilt; Leg light, Low Fuel; Cage Overload; Low Oil Pressure	
<b>9</b> Joystick Switch on top of Joystick	<b>Forward</b> = Drive forward <b>Left</b> = Left	<b>Backward</b> = Drive reverse <b>Right</b> = Right
<b>10</b> Rear Steer	<b>Left</b> = Left	<b>Right</b> = Right
Jackleg switches (Above Control Panel)	Depress Outer Edge = Deploy	Depress Inner Edge = Retract

**BOOM FUNCTIONS**

- 1) Push and hold green "Power Control" button.

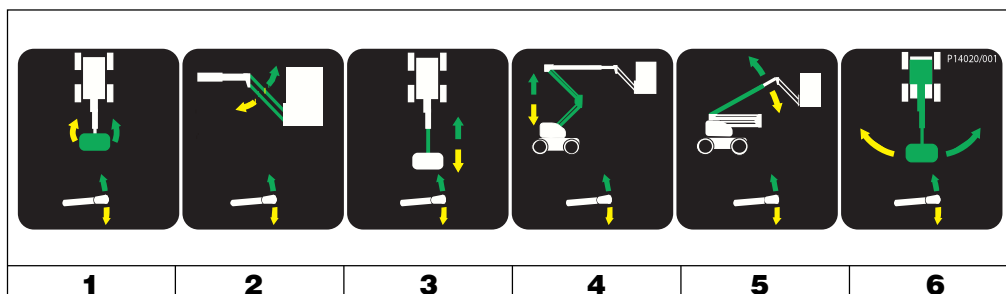

- 2) Select lever 1, 2, 3, 4, 5 or 6 for desired function.

<b>1</b> Operates Basket Rotation	<b>UP</b> for clockwise	<b>DOWN</b> for anti-clockwise
<b>2</b> Operates Flyboom	<b>UP</b> for up	<b>DOWN</b> for down
<b>3</b> Operates Telescoping	<b>UP</b> for out	<b>DOWN</b> for in
<b>4</b> Operates Links	<b>UP</b> for up	<b>DOWN</b> for down
<b>5</b> Operates Luffing boom	<b>UP</b> for up	<b>DOWN</b> for down
<b>6</b> Operates Boom Rotation	<b>UP</b> for right	<b>DOWN</b> for left

## Operating & Safety Instructions

### 4.4.2 SiOPS™ - LOAD SENSING CONSOLE (If fitted)



**WHEN OPERATING THIS MACHINE THE USER MUST BE AWARE OF ANY OVERHEAD OBSTRUCTIONS.**

This machine incorporates a load sensing cage console that senses if the operator has been pushed or has fallen against the console. If the load applied to the front of the console is greater than the pre-determined amount, the footswitch will be disabled to increase operator safety and reduce the possibility of sustained involuntary operation of the cage controls.

**Note:** The green button will illuminate once the footswitch has been disabled, but continues to be available for use at all times. This allows the operator to use the cage control functions and manoeuvre the machine to a safe position.

To reset the footswitch:

- 1) Release the load from the front of the console.
- 2) Ensure cage controls are in the neutral position and clear of objects.
- 3) Raise foot clear of footswitch then lower foot onto footswitch.
- 4) Footswitch is now active and full control has been restored.

**Note:** If SiOPS™ has been activated and the footswitch is not reset within **15 seconds**, then the blue warning beacon will flash (If fitted, located on underside of the cage) until the footswitch is reset as described previously.

## 4.5 DRIVING CONTROLS



**Do not operate the Niftylift whilst elevated unless on a firm, level surface free from any possible obstructions or hazards both at ground level and overhead.**

- 1) Using the electric luffing switch on the basket console, elevate the basket to the drive position for better visibility. This elevates the basket approximately 1m above the ground.
- 2) Check proposed route for possible hazards, obstructions and personnel.
- 3) Depress switch located on the front of the joystick.
- 4) Use the Drive Speed selectors on the basket control station to determine speed.
  - 1/2** (Tortoise) - gives low speed and low engine revs.
  - 2/2** (Hare) - gives high speed and high engine revs.Set the **variable speed** control knob as required.
- 5) Select drive joystick located on the basket console.
  - Push forward for **FORWARD DRIVE**
  - Pull backward for **REVERSE DRIVE**

Front steering is controlled by the rocker-switch button on the top of the joystick

Left for **STEER LEFT**

Right for **STEER RIGHT**

Rear steering is controlled by the rocker-switch button located in front of the joystick

Left for **STEER LEFT**

Right for **STEER RIGHT**

All control levers give a fully proportional response therefore the more the lever is moved away from the centre OFF position the faster the function will become.

Maximum drive speed is only attainable when the variable speed control knob is set to maximum and the joystick is pushed fully forward.

When driving with the booms fully stowed, the Niftylift can be driven up and down slopes with an inclination of 24°. However, the tilt alarm operates a sounder and warning lamp on the basket control panel, warning the operator that the machine is operating on a slope greater than or equal to 10°. **Great care must be taken at all times when manoeuvring any machine on slopes greater than 10°.** If in any doubt as to the stability of the machine whilst operating across a slope, partially deploy the downhill outriggers for additional safety.

Under no circumstances should any SD64 series machine be driven on slopes exceeding the gradeability in the general specification.

## **4.6 OUTRIGGERS**

Before elevating the booms, the operator must first deploy and set up each of the outriggers using the switches on the basket console until the base is level. The level of the machine can be checked using the spirit level located on top of the base. To ensure that all of the outrigger feet are correctly deployed, check that the light on each of the outrigger switches has turned off.

As soon as any one of the outrigger feet makes contact with the ground and starts taking load, then the operating speed is reduced. This is to provide safer and smoother control of the outriggers.

Once the outriggers are correctly set up, the operator can use all boom functions. Should an outrigger foot come clear of the ground while any of the booms are out of its stowed position, an audible siren will sound as well as a flashing warning light on the basket console. Also the light on the switch that controls that particular stabiliser will light up again indicating which one has gone light. If this happens, return all booms to their stowed position. This will return control to the outriggers allowing them to be reset.



## 4.7 BASKET WEIGH SYSTEM (Optional)

### 4.7.1 LOAD CELL VERSION

The Niftylift SD210 is fitted with an electronic load cell. This load cell is a moment-independent, redundant design. This means that independent of the load position inside the basket of the machine, the actual load is measured and if pre-configured limit values are exceeded, warnings will be activated. "Redundant design" means that the load cell design incorporates dual channels that monitor each other. The design of the unit meets the requirements of both BS ANSI A92.20 and ISO 13849 with a safety integrity level of "Category 3 PL d".

### 4.7.2 FUNCTION

The machine informs the operator, via the load cell output, of the current state of the machine with regard to basket load. The red lamps warning the operator of an overload condition are located on the basket control panel (see section 4.4.1) and the base control panel (see section 4.3.1). Refer to following table;

Lamp	Description	Load value	Machine Behaviour
Flashing red (Safety Warning Lamp)	Load in the basket has exceeded safe working load	Above 225kg	Controls isolated – safely remove excess load to restore normal operation

### 4.7.3 CALIBRATION, INSPECTION AND MAINTENANCE

Calibration, maintenance and repair of the Niftylift SD210 basket load cell require specialist knowledge and equipment. **For this reason, no part of the electronic cage-weigh system can be adjusted, repaired or inspected by the operator.**

All enquiries relating to calibration, inspection or maintenance should be directed to Niftylift or one of Niftylift's approved dealers. Contact details are listed in Section 1.4.

## **4.8 TRANSPORTING, TOWING, CRANEAGE, STORAGE AND SETTING TO WORK**

### **4.8.1 TRANSPORTING**

If a Niftylift is to be moved over a longer distance, whether the machine is trailer mounted, vehicle mounted, self-propelled or tracked, the following procedure should be read before restraints are attached to the machine. Cross loading is most frequently the cause of problems, as the method of loading is no longer under the control of our own personnel. The recommendations made herein should be passed on to subsequent carriers, such that the entire journey is carried out without incident.

- Always ensure the truck or trailer you are loading or towing the Niftylift with can carry it legally.
- If loading by crane the use of shackles and an adequately rated spreader beam, with four leg slings around indicated slinging points on base, is **MANDATORY**.
- When loading or un-loading from the side of the vehicle, the use of the forklift pockets to retain one of the forks is recommended. (If fitted). Spread the forks to their widest capacity, with due regard to the components fitted to the Niftylift. Never forklift or crane an entire Niftylift under the booms, always lift beneath the spine or under the ends of the axle mountings in the case of a self-propelled unit. Ensure forklift is adequately rated for the load to be carried.
- Once positioned on the transport carrier, ratchet straps should be used to secure the Niftylift. Pass the strap over the bosses located in the bottom of all four outrigger housings on the base and secure to the transport carrier. The Niftylift should be positioned to allow easy access around the machine in transit, and to ensure that 'creepage' during transport does not permit the machine to come into contact with other goods being shipped, or the container itself. Some movement of the Niftylift structure might occur during transit, which could lead to fretting or other damage.
- If the Niftylift is equipped with a transit device such as a boom clamp etc, this should be securely applied.
- Strap booms carefully to constrain them from sideways movement. When using straps or chains, adequate packing should be applied to stop any damage to the structure and paintwork. Due regard of the movement of the straps or chains must be taken into account.
- Where a Niftylift has designated points for strapping, lifting or forking, these can be used for tie-down duty. When they are absent, the major structure of the Niftylift can be used, giving due consideration to the design and function of the area chosen. Where possible, use the spine of the Niftylift or axle mounts over which to apply the holding down forces. Using a single plate, such as an outrigger or stabiliser support plate might be unsuitable. If the component was clearly not designed to accommodate a side load, one should not be applied.
- Under no circumstances should straps or chains be applied over booms or through the basket support structure or the basket itself. The relative strength of the carrying structure is not conducive to the massive forces capable of being applied through ratchet chains or slings. Severe damage to the steelwork can be caused, as well as deformation to sensitive mechanisms such as basket weigh assemblies, which would render them useless. Such catastrophic damage to say, an electronic load cell would require the component to be replaced before the machine would function.

#### 4.8.2 TOWING



**DO NOT TOW MACHINE WITHOUT FOLLOWING THE TOWING PROCEDURE AS DESCRIBED IN SECTION 5.4 OF THIS MANUAL.**

#### 4.8.3 CRANEAGE

- 1) Observe all of the limitations relating to straps and chains stated above under 'Transporting'. (4.8.1)
- 2) When utilising the designated lifting points never apply a 'snatch' load, i.e. lift slowly to take up the load before raising. Similarly, do not drop machine when positioning after lifting.
- 3) If the machine is to be lifted by crane, use the designated lifting points and observe the recommendations regarding spreader beams. Individual drawings are available for each machine type, on request. (See list below.)

D81489  
D80891  
**D81338**

SD34T  
SD50  
**SD64**

#### 4.8.4 STORAGE

If being stored for any length of time without use, then the machine should be thoroughly inspected for the following: -

- 1) Grease all bearings /slides, worm drives, etc.
- 2) If machine is to be left on an incline, chock wheels to prevent creep.
- 3) If machine is to be left outdoors or in a hostile environment, cover with suitable weatherproof media to prevent deterioration.

### **4.8.5 SETTING TO WORK**

Before use each day and at the beginning of each shift the machine shall be given a visual and functional test including, but not limited to, the following;

- 1) Check all lubrication points for adequate application of grease, oil etc.
- 2) Inspect all threads for ease of operation.
- 3) Check level and quantity of oil. Remove any contaminants - water, etc.
- 4) Check battery for electrolyte and state of charge.
- 5) Check electrics for damage and insulation.
- 6) Using base controls, cycle machine over complete envelope in accordance with the Operating Instructions. Cure any defects.
- 7) Ensure that all safety devices and controls operate in accordance with the instructions.
- 8) If necessary, perform a load test to establish the machine stability before putting the Niftylift to work.
- 9) On completion of an extended period of road transport, the Niftylift might need additional inspection to identify any transit degradation, which could render the machine unsafe. Perform a P.D.I. inspection on the unit before it enters service. Record any faults found and rectify them immediately.
- 10) If left un-attended for an extended period, it is likely that the hydraulic basket levelling will become un-pressurised. Normal operation is then lost, with a noticeable delay in the forwards or backwards motion as the booms move. To restore normal function, the basket needs to be fully levelled forwards and backwards, using the basket-levelling lever whilst **not** standing in the basket (i.e. with the operator standing adjacent to the basket side whilst simultaneously operating the lever and green button to move the basket). Take care not to become trapped between the moving basket and a fixed object, and ensure those around you are clear of the moving basket. When the system has been charged in both directions, the basket levelling function should be restored. If the system operates but is 'jerky' in either direction, this indicates air in the system. Repeat the procedure as described above until the movements are smooth and un-interrupted. If in doubt, contact our Service Department for further advice.

Niftylift Limited is not liable for any third party damage caused during transport. Careful attention to correct procedures will prevent many of the small snags that can happen in transit. Re-work is both expensive and time consuming. A defective machine arriving at the place of work is a poor advertisement for our product, the company's reputation and those of our dealers and clients. The responsibility for safe and damage-free transport rests with the haulier or his representatives.

## 5 Emergency Controls

### 5.1 GENERAL



**CHECKING THE OPERATION OF THE EMERGENCY CONTROLS EVERY DAY AND/OR BEFORE EACH SHIFT IS AN ESSENTIAL PART OF THE OPERATOR'S DUTIES**

The operator and all ground personnel must be thoroughly familiar with the location and operation of the **EMERGENCY CONTROLS**.

### 5.2 IN THE EVENT OF AN INCAPACITATED OPERATOR

Turn the **Base/Basket** Selector in the ground control station to **ground** (clockwise). Then lower on the ground controls as detailed under section 4.3 Ground Control Operation.

### 5.3 IN THE EVENT OF MACHINE FAILURE

Operate manual hand pump (located under control cover) and lower basket to the ground using either basket or base controls. If initial movement of the machine allows the master alarm to reset, normal controls will be available. This is then the fastest method of lowering the basket to the ground.

Opening the nearside machine canopy reveals the ground controls, plus the dedicated hydraulics for emergency recovery of the machine.



Primarily there are two emergency hand pumps, the first is mounted separately and adjacent to the ground control valve block and is used for the boom functions and jack legs. The second hand pump is incorporated into the Drive Control Valve Block and is used for the brake release and front steering.

# **nifty** SD64 Series

---

## **Operating & Safety Instructions**

### **5.3.1 BOOM OVERRIDE**

Ensure the Diverter Valve handle is turned to the right (see below). Operate the appropriate function, and using the Booms Hand Pump, manoeuvre the booms as required. If desired, the Basket operator can hold the appropriate lever to manoeuvre the machine, whilst a ground operative provides the motive power using the booms hand pump. When not in use, the handle should be stowed back in its clips.



**FOLLOWING AN EMERGENCY DESCENT RECOVERY OF THE BASKET, FULLY EXTEND AND RETRACT ALL CYLINDERS FROM GROUND CONTROL STATION BEFORE USING THE MACHINE**

### **5.3.2 FRONT STEER OVERRIDE**

Push the CT15 Override fully in and hold, or pull fully out and hold. Now use the Integral Hand Pump to operate the front steer function. The push or pull function of the CT15 Override determines either left or right steer operation.

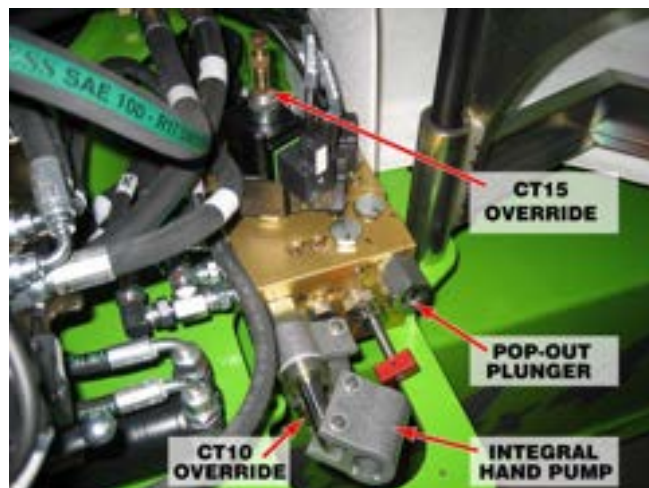

## 5.4 TOWING

If the Niftylift needs to be towed in case of an emergency, it will be necessary to **chock the wheels** before commencing gearbox disengagement.

### 5.4.1 IDENTIFYING GEARBOX TYPE

To safely tow the SD210, the drive mechanism will need to be bypassed. Identify the type of gearbox fitted to the machine then refer to the relevant procedure for disengagement of the gearboxes.

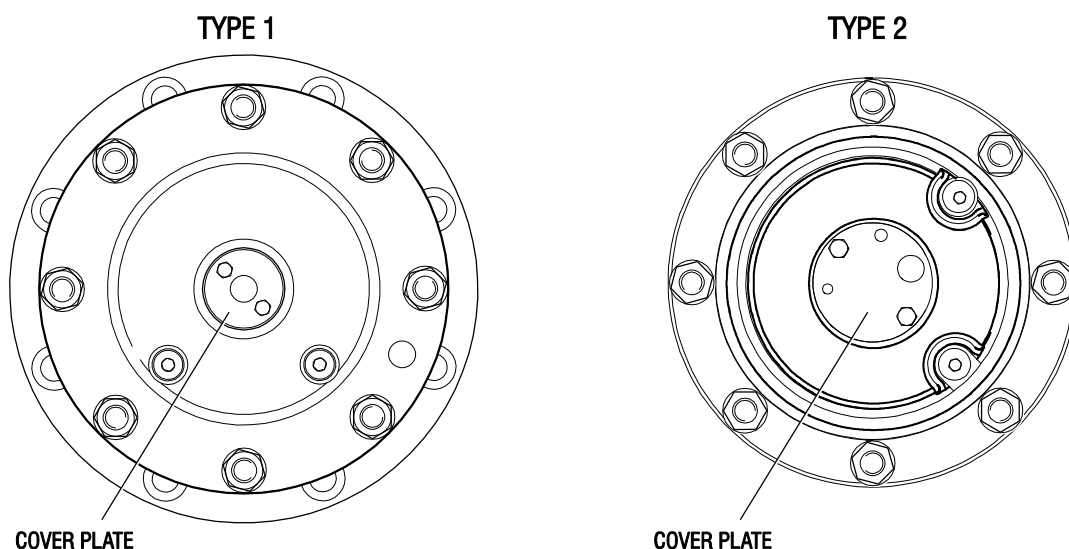

### 5.4.2 GEARBOX DISENGAGEMENT (TYPE 1)

The drive gearboxes located on the front and rear wheel hubs must be disengaged as follows;

- 1) To disengage the gearbox, remove both screws from the cover plate, turn it upside down (as per the diagram below), re-tighten the M5 screws to a torque of 5 Nm (3.7lbft).
- 2) Before attempting to re-engage the gearbox, ensure that the machine is jacked up so the relevant wheel is clear of the ground in order to prevent damage. **Note; Damage caused by failure to comply with this notice will not be covered by the manufacturer's warranty.**

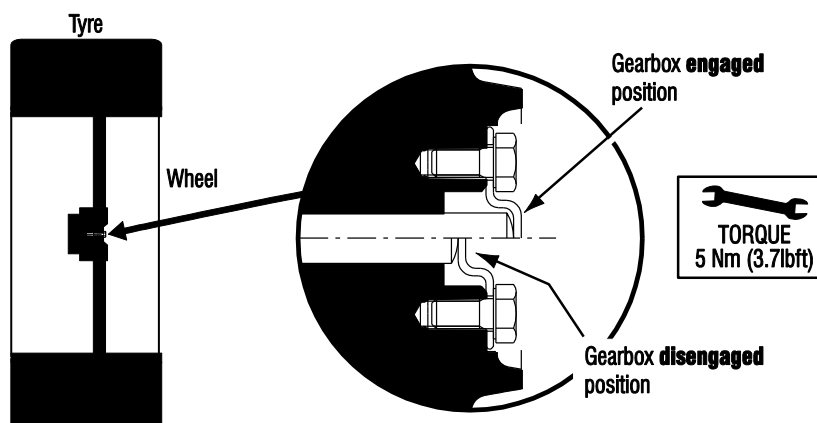

## Operating & Safety Instructions

### 5.4.3 GEARBOX DISENGAGEMENT (TYPE 2)

The drive gearboxes located on the front and rear wheel hubs must be disengaged as follows;

- 1) Remove both retaining bolts that secure the cover disc to the centre of the wheel hub.
- 2) Partially screw one of the retaining bolts into the end of the central disengage pin and pull the pin out fully, ensuring the recess on the pin is visible.
- 3) Place the cover disc over the pin, ensuring the retaining disc is engaged in the pin recess and secure in place using the remaining retaining bolt.
- 4) To re-engage the gearbox, complete the above instructions in reverse order, ensuring gearbox drive is free to engage before pushing the pin 'home'. If necessary, jack up each wheel & rotate slightly to allow re-engagement of pin.

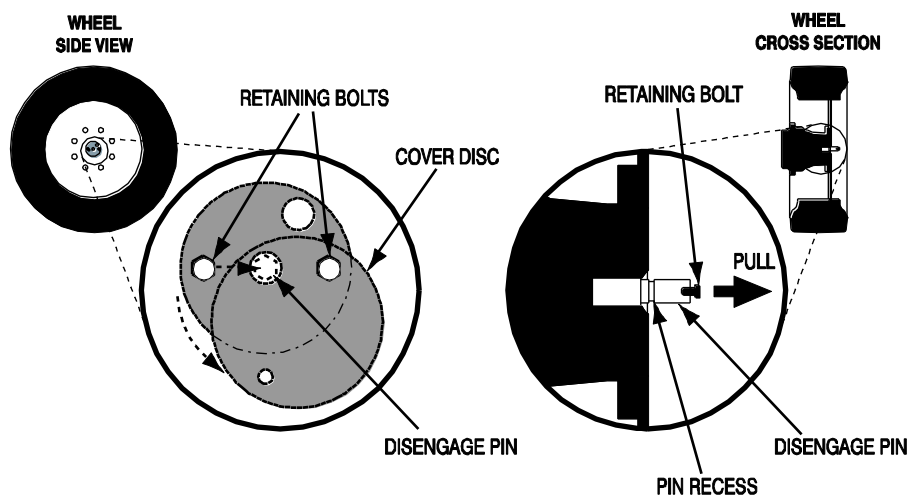

### 5.4.4 BRAKE RELEASE FOR TOWING

To tow the machine it is necessary to bypass the parking brakes. First, ensure that the machine is restrained against running away, i.e. suitably position the towing vehicle and attach a rigid tow bar to the towing hoops located at both ends of the chassis and adequately chock on two or more wheels in both directions. **Moving the Niftylift must not be attempted until adequate means to prevent it from rolling away are in place.**

Fit the hand pump handle to the Integral Hand Pump. Push and hold down the CT10 Override whilst pumping the handle. When brake pressure is generated, the brake Pop-Out Plunger will be exposed.

The brakes are now bypassed and the Niftylift is capable of being towed at a low speed.

To re-set the parking brakes, the CT8 Override Tap should be fully opened (turn anti-clockwise).

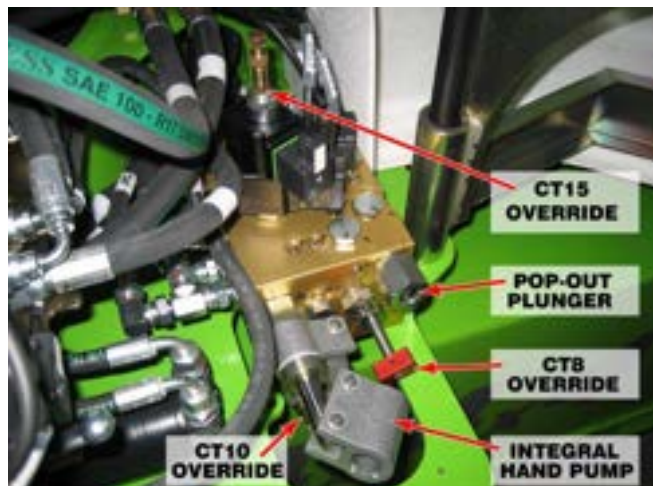



This is the red knob on the side of the Drive Control Valve block. Opening this knob allows the brake pressure to dissipate from the bypass circuit, re-setting the parking brakes and de-energizing the tow valve. The Niftylift will now lock the wheels and deny any attempt at towing.

Once complete ensure that the CT8 Tap is returned to its fully closed position.

For safety, the Niftylift should not be left with the brakes bypassed. If the Niftylift has to be left with the brakes bypassed, ensure wheels are chocked and suitable placards are attached to the Niftylift to warn operators of this condition.

#### 5.4.5 MANUAL OUTRIGGER RECOVERY



**IMPORTANT: ALWAYS STOW ALL OF THE BOOMS BEFORE USING THIS FUNCTION. FAILURE TO DO THIS CAN RESULT IN SERIOUS INJURY OR DEATH!**

**Note; Two persons are required for this procedure.** To manually recover the outriggers in the event of loss of power, ensure the Diverter Valve handle is turned towards the operator (see Section 5.3.2) and both the CT17 Tap (red) and CT20 Tap (gold) are fully closed. Next either push the outrigger override fully in and hold, or pull fully out and hold. Now use the Booms Hand Pump to operate the outrigger function. The push or pull function of the Outrigger Overrides determine whether the outriggers are deployed or retracted. The two Outrigger Overrides operate either the left or right outrigger and are located in both ends of the chassis by removing the end covers. Return the diverter valve handle to booms position (facing right) to allow canopy to close. This ensures that the hand pump always defaults to 'booms' position when needed'.

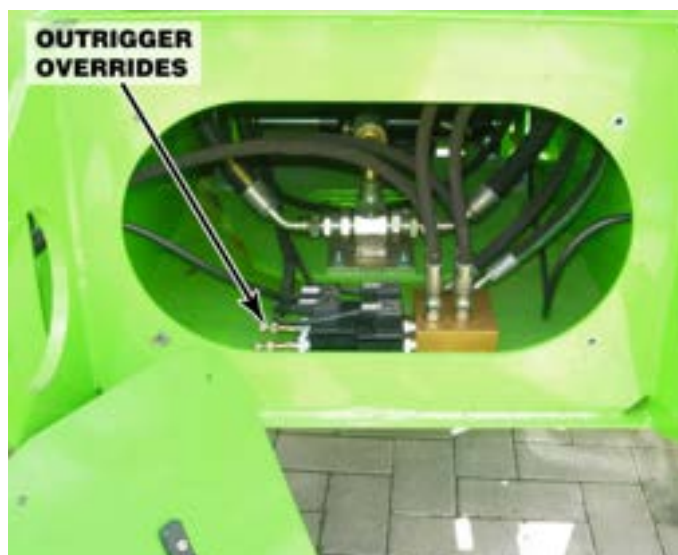

#### 5.5 INCIDENT NOTIFICATION

It is a mandatory requirement that any accident or incident involving a Niftylift is reported by telephone directly to Niftylift, regardless of whether any party received injury or property was damaged. Failure to do so may render any warranty on the machine void.

## **6 Responsibilities**

### **6.1 CHANGES IN OWNERSHIP**

When a change of ownership of a Niftylift occurs, it shall be the responsibility of the seller to notify Niftylift direct of the unit, model and serial number and the name and address of the new owner within 60 days. This important step is required so that all future Technical Bulletins are able to reach the registered owner of each Niftylift without delay. Please note warranties are not transferable.

### **6.2 MANUAL OF RESPONSIBILITIES**

You are required by ANSI/SAIA A92.20 2018, to read and understand your responsibilities before you use or operate this aerial basket.

Please read the enclosed document, as failure to do so could result in death or serious injury.

Wherever any contradiction may appear, the Manual of Responsibilities shall take precedence over all other documents.

**6.3 INSPECTION/SERVICE/PRE-HIRE CHECK LIST**

**MACHINE SERIAL NO** \_\_\_\_\_

<b>TOWING</b>	<b>PASS</b>	<b>FAIL</b>	<b>N/A</b>
Check brakes are released or...			
Check wheel gearboxes disengaged			
<b>OUTRIGGERS</b>			
Micro-switches secure			
Operation of each micro-switch and klaxon			
Operation of outrigger control valve and buttons			
Operation of each hydraulic outrigger			
Operation of boom rest micro-switch			
<b>AXLES, WHEELS AND BRAKES</b>			
Axles are secure			
Wheels are secure, tire condition acceptable			
Axle holding bolts secure			
Tire pressure correct			
Wheel nut torque correct			
<b>BASE</b>			
Operation of Emergency Stop button			
Operation of base control valve and buttons			
Operation of all booms over full range			
Cylinders are silent			
Basket is level over full range			
Booms, levelling rods not damaged or distorted			
Booms, levelling, cylinders not fouling			
Hoses not tight, kinked or fouled			
Operation of emergency hand pump			
<b>BOOM ROTATION</b>			
Boon rotation assembly and motor are secure			
Worm/wheel mesh correct, no excessive wear			
No end float of worm in housing			
Boom rotation gear wheel bolts secured			
Boom rotation gear guards secure			

**nifty SD64 Series**

**Operating & Safety Instructions**

<b>BASKET</b>	<b>PASS</b>	<b>FAIL</b>	<b>N/A</b>
Operation of Emergency Stop button			
Operation of control valve and buttons			
Operation of SiOPS			
Operation of all booms over full range			
Cylinders are silent			
Basket levelling over full range			
Boom rotation smooth over full range			
<b>INTERNAL (POWER PACK)</b>			
Power pack and all components secure			
All cables and terminals secure			
All hose connections secure			
Hoses not kinked or fouled			
Charger/control box secure			
Battery secure			
Electrolyte level and specific gravity			
Charger operation			
Hydraulic oil level			
<b>FINISH</b>			
Serial plate against documentation			
Swing bolts			
Correct decals, all visible			
Canopy/bonnets			
Grease nipples (Tow coupling, Boom rotation gear ring)			
<b>LEAK CHECK</b>			
Cylinders (Lift, Outriggers, Telescope, Levelling)			
Control valves			
Check valves			
Power pack/pump			
Boom rotation motor			
Hose connections			

**Comments, remedial work required etc;**

**INSPECTED BY:** \_\_\_\_\_

**DATE:**    /    /

***niftylift***